

Plan VIP75840  
A

Plan VIP75840  
A

**SITE DATA**

LOCATION:	1073 COLVILLE ROAD - ESQUIMALT			
BUILDING TYPE:	MULTI-FAMILY SUBDIVISION			
ZONING:	RD-1 EXISTING			
ZONING REQUIREMENTS	REQUIRED RD-1	LOT A	LOT B	COMMENTS
LOT AREA	668.00 M <sup>2</sup>	415.82 M <sup>2</sup> 4475.95 FT <sup>2</sup>	490.03 M <sup>2</sup> 5274.72 FT <sup>2</sup>	VARIANCE - BOTH LOTS
CURB CROSSING	4.50 M WIDE MAX	13.24 M 43.43 FT	13.26 M 43.50 FT	
LOT WIDTH	NA	18.29 M 60.00 FT	18.29 M 60.00 FT	
SETBACKS				
FRONT	4.00 M	6.72 M 22.04 FT	6.33 M 20.76 FT	
REAR	4.50 M	4.50 M 14.76 FT	4.73 M 15.51 FT	
SIDE EAST	1.50 M	1.52 M 4.98 FT	1.60 M 5.24 FT	
SIDE WEST	1.50 M	1.53 M 5.02 FT	1.60 M 5.24 FT	
SIDE COMBINED	3.00 M	3.05 M 10.00 FT	3.20 M 10.49 FT	
AVERAGE GRADE	NA	12.84 M 42.12 FT	10.90 M 35.76 FT	
BUILDING HEIGHT	NA	7.44 M 24.40 FT	8.05 M 26.41 FT	
BUILDING AREA				
UPPER FLOOR AREA	NA	129.84 M <sup>2</sup> 1397.65 FT <sup>2</sup>	192.30 M <sup>2</sup> 2068.91 FT <sup>2</sup>	
MAIN FLOOR AREA	NA	131.97 M <sup>2</sup> 1420.56 FT <sup>2</sup>	185.89 M <sup>2</sup> 2000.92 FT <sup>2</sup>	
LOWER FLOOR AREA (GARAGE INC.)	NA	NA	188.02 M <sup>2</sup> 2023.84 FT <sup>2</sup>	
GARAGE AREA	NA	NA	68.82 M <sup>2</sup> 740.86 FT <sup>2</sup>	
GARAGE ALLOWANCE	UP TO 40.00M <sup>2</sup> PER UNIT	NA	-68.82 M <sup>2</sup> - 740.86 FT <sup>2</sup>	
BASEMENT ALLOWANCE	NA	NA	-94.95 M <sup>2</sup> - 1022.10 FT <sup>2</sup>	
TOTAL FLOOR AREA	NA	261.81M <sup>2</sup> 2818.21 FT <sup>2</sup>	403.24M <sup>2</sup> 4076.36 FT <sup>2</sup>	
SECONDARY SUITE AREA	40% PRINCIPAL FLOOR AREA	NA	30.82 M <sup>2</sup> 331.80 FT <sup>2</sup>	
FAR	NA	0.62	0.82	
BUILDING FOOTPRINT	NA	183.14M <sup>2</sup> 1971.32 FT <sup>2</sup>	211.56M <sup>2</sup> 2277.27 FT <sup>2</sup>	
MAXIMUM LOT COVERAGE	50%	40.53%	43.17%	
% OF LOT PERIMETER AT HWY	NA	0.00%	0.00%	
TREES TO BE REMOVED	NA	0	6	SEE ARBOURIST PLAN
PARKING AND ELECTRIC CHARGING	1 WITH CHARGING	3 (3 CHARGING)	3 (3 CHARGING)	
TOTAL OPEN SITE SPACE	NA	137.96 M <sup>2</sup> 1485.03 FT <sup>2</sup>	139.56 M <sup>2</sup> 1502.26 FT <sup>2</sup>	
BIKE PARKING	NA	6 SPACES	6 SPACES	

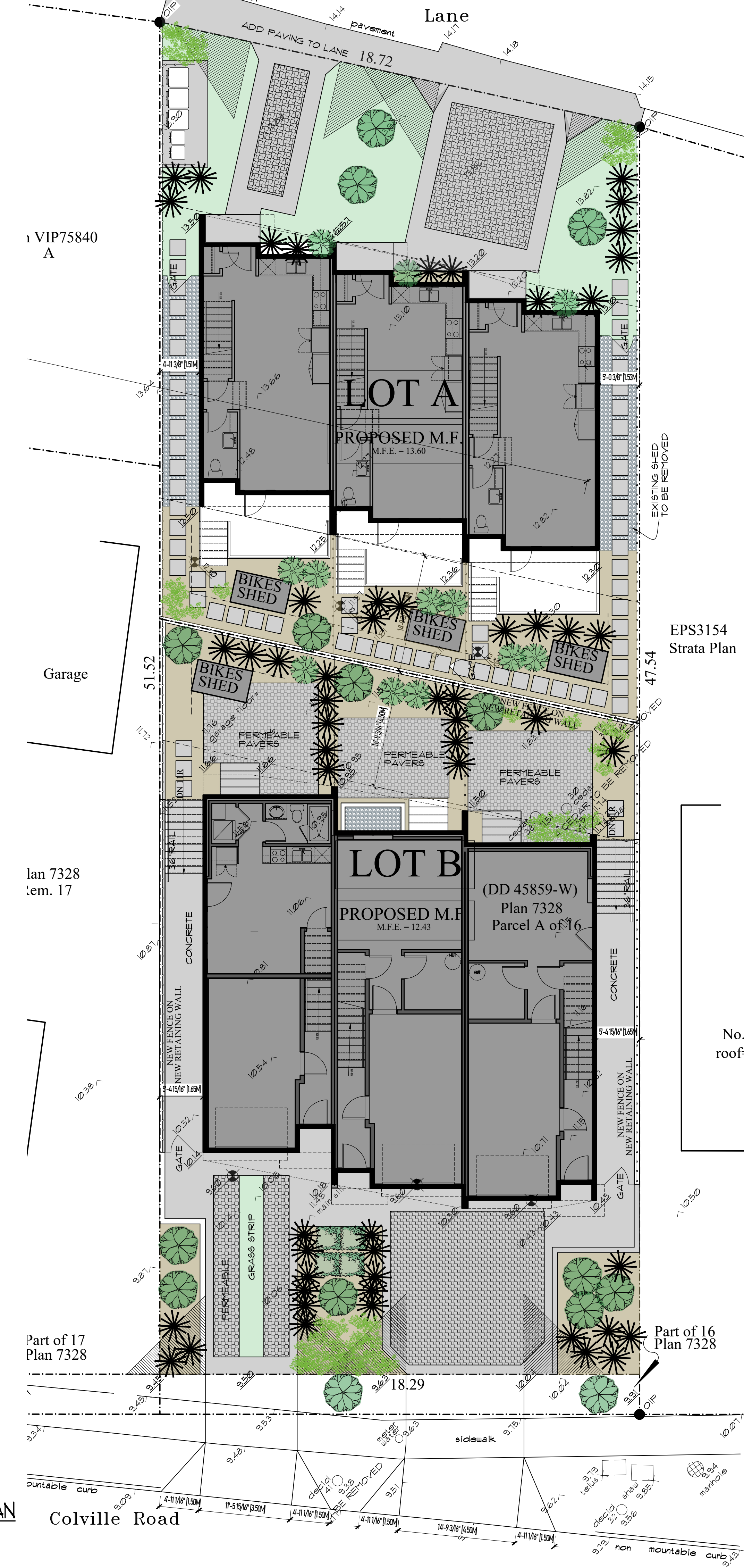
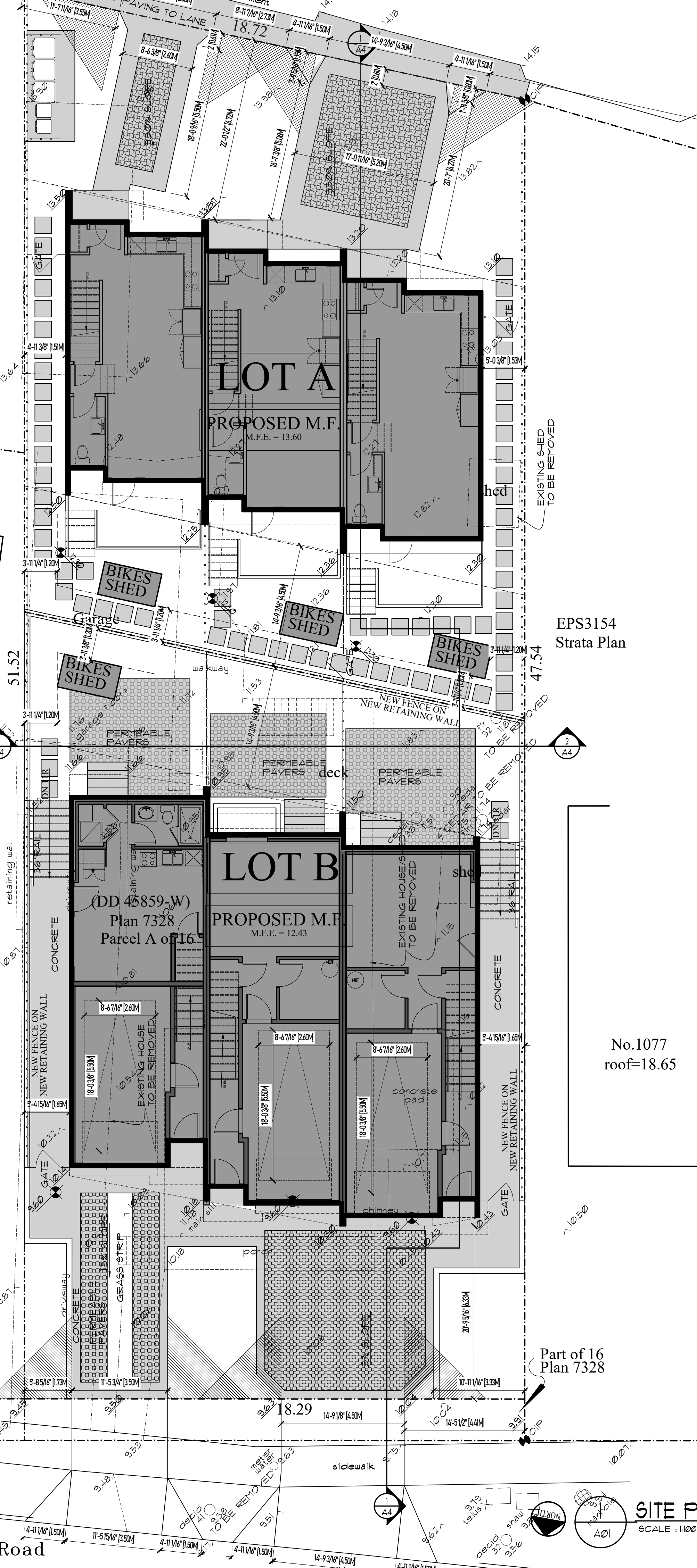

**LANDSCAPE PLAN LEGEND**

**TREES AND SHRUBS**

EXISTING TREE NEW TREE NEW SHRUBS GROUNDCOVER PLANTS

**GROUNDCOVER**

MULCH LAWN GRAVEL

**HARDLANDSCAPING**

PERMEABLE PAVERS BROOM FINISHED CONCRETE CONCRETE PAVERS

EXISTING SIDEWALK PAVING

FENCE WOOD (STAINED) 6' HIGH

EGRESS PRIMARY EGRESS SECONDARY EGRESS

**NOTES:**

- LANDSCAPING INDICATED IS CONCEPTUAL ONLY AND REQUIRES INSTALLATION BY A QUALIFIED LANDSCAPING CONTRACTOR.
- CONTRACTOR TO IDENTIFY UTILITIES PROVIDED THROUGH UNDERGROUND WIRING AND AVOID CONFLICT WITH EXCAVATIONS.
- ALL LANDSCAPING SHALL BE PERFORMED TO BCSLA, BCINA STANDARDS
- ALL EXISTING TREES TO REMAIN, UNLESS NOTED OTHERWISE.
- WOOD FENCE TO BE MAX HEIGHT OF 1800MM (4'-0") BETWEEN FRONT PROPERTY LINE AND FRONT OF BUILDING 1800MM (6'-0") BETWEEN FRONT OF BUILDING AND REAR PROPERTY LINE

**SUGGESTED PLANTING LIST**

TREES	BOTANICAL NAME	COMMON NAME	SIZE
	CORRUS VENUS	FLOWERING DOGWOOD	25M HT. B4B
	CAEILIA JAPONICA SPECIMEN	EVERGREEN CAEILIA	30M HT. B4B
	CAEILIA JAPONICA	CORK TREE	25M HT. B4B
	QUERCUS GARRYANA	GARRY OAK	30M HT. B4B
SHRUBS	BOTANICAL NAME	COMMON NAME	SIZE
	ARBUTUS UNEDO COMPACTA	STRAWBERRY TREE	30M HT. B4B
	BERBERIS THUNDERGILL ATROPURPUREA	BARBERRY	30M HT. B4B
	BUXUS MICROPHYLLOLLA	DWARF BOXWOOD	30M HT. B4B
	CAEILIA JAPONICA	RED CAEILIA	30M HT. B4B
	CISTIS LADANIFER	CRIMSON ROCK ROSE	30M HT. B4B
	CELANOTHUS GLORIOSUS INORABRE	PROSTRATE MOUNTAIN LILAC	30M HT. B4B
	WHITE HEATH	WHITE HEATH	30M HT. B4B
	ERICA X DARLEYNSIS FURZEY	PINK HEATHER	30M HT. B4B
	ERSCALLONIA NEWPORT DWARF	DWARF ERSCALLONIA	30M HT. B4B
	HEBE 'FAT TY'S PURPLE'	HEBE	30M HT. B4B
	LAVENDULA ANGIUSTIFOLIA HIDCOTE	HIDCOTE LAVENDER	30M HT. B4B
	RIBES SANGUINEUM KING EDWARD	PINK FLOWERING CURRANT	30M HT. B4B
	RHOXODENDRON	WHITE RHODODENDRON	30M HT. B4B
	SPIREA FRUNIFOLIA	BRIDAL WREATH SPIREA	30M HT. B4B
	VIBURNUM DAVIDII	EVERGREEN VIBURNUM	30M HT. B4B
GROUND COVER	BOTANICAL NAME	COMMON NAME	SIZE
	PARTHENOCISSUS QUINQUEFOLIA	VERGIN CREEPER	6P3, 30CM O/C
	THYMUS PINK RIFFLE	CREEPING THYME	6P3, 30CM O/C

**NOTES:**

PLEASE SEE THE ARBOURISTS TREE MANAGEMENT PLAN FOR THE REMOVAL AND REPLACEMENT OF TREES INDICATED IN THE REPORT.

**DRAWING LIST**

- A1 SITE PLAN, LANDSCAPE AND SITE DATA
- A2 LOT A PLANS, ELEVATIONS, SECTIONS AND LOT B STREETScape
- A3 LOT B PLANS, ELEVATIONS, 4 SECTIONS
- A4 SITE SECTIONS

RE-ISSUED FOR DVP  
2025-09-12



1161 NEWPORT AVE  
Victoria, B.C. V8S 5E6  
Phone: (250) 360-2144  
Fax: (250) 360-2115

Drawn By: LOUIS HORVAT  
Date: JANUARY 27, 2023  
Scale: AS NOTED

Project:  
1073 COLVILLE ROAD  
SUBDIVISION AND  
REZONING

Title:  
SITE PLAN AND  
LANDSCAPE PLAN

Revision: Sheet:  
**A1**  
Proj.No.

**SITE PLAN**  
SCALE: 1:100

**2 LANDSCAPE PLAN**  
SCALE: 1:100

FINISH SCHEDULE	
1	CEMENTITIOUS PANEL COLOUR: WHITE MANUFACTURER: JAMES HARDIE
2	CEMENTITIOUS PANEL COLOUR: DARK GREY MANUFACTURER: JAMES HARDIE
3	CEMENTITIOUS SIDING COLOUR: BLUE MANUFACTURER: JAMES HARDIE
4	PREFINISHED METAL COLOUR: DARK GREY MANUFACTURER: .
GENERAL NOTES:	
- WINDOWS AND DOORS TO BE TRIMMED WITH 35' WIDE VERTICAL BOARDS, 8' HEAD BOARD, BASE 2' WATERABLE 35' TRIM-COLOUR TO MATCH PREFINISHED METAL COLOUR	
- WINDOW OPERATION SHALL BE PER OWNER'S DIRECTION AND CONFORM TO B.C.B.C. 2018 REQUIREMENTS FOR EGRESS	
- FLASH OVER ALL MATERIAL TRANSITIONS, AND DOOR & WINDOW HEADS	
- NO COMBED-FACED TRIM	
- ALL COLOURS BY DESIGNED AND OWNER	

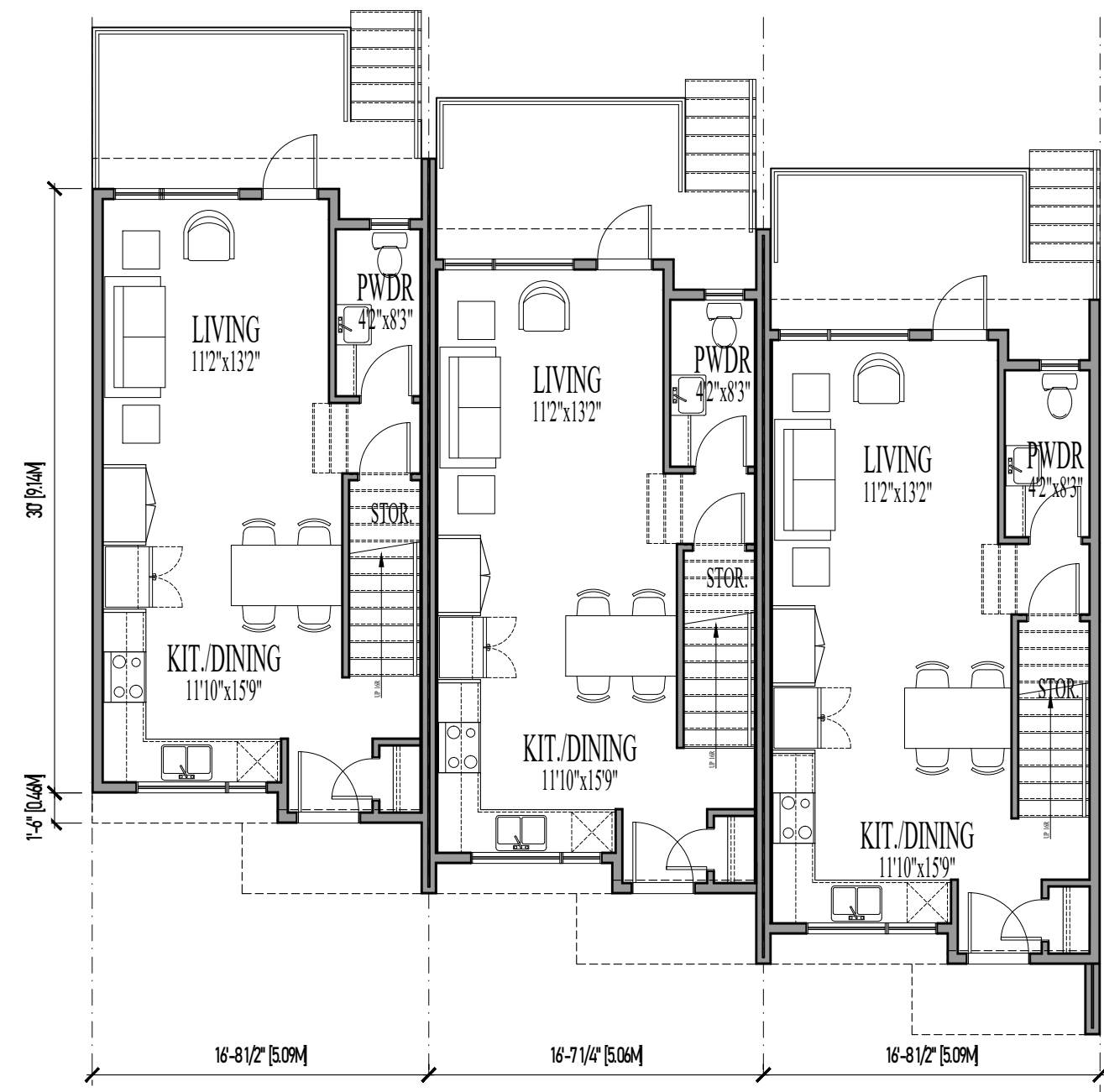

1 MAIN FLOOR PLAN-LOT A  
SCALE: 1/8"=1'0"

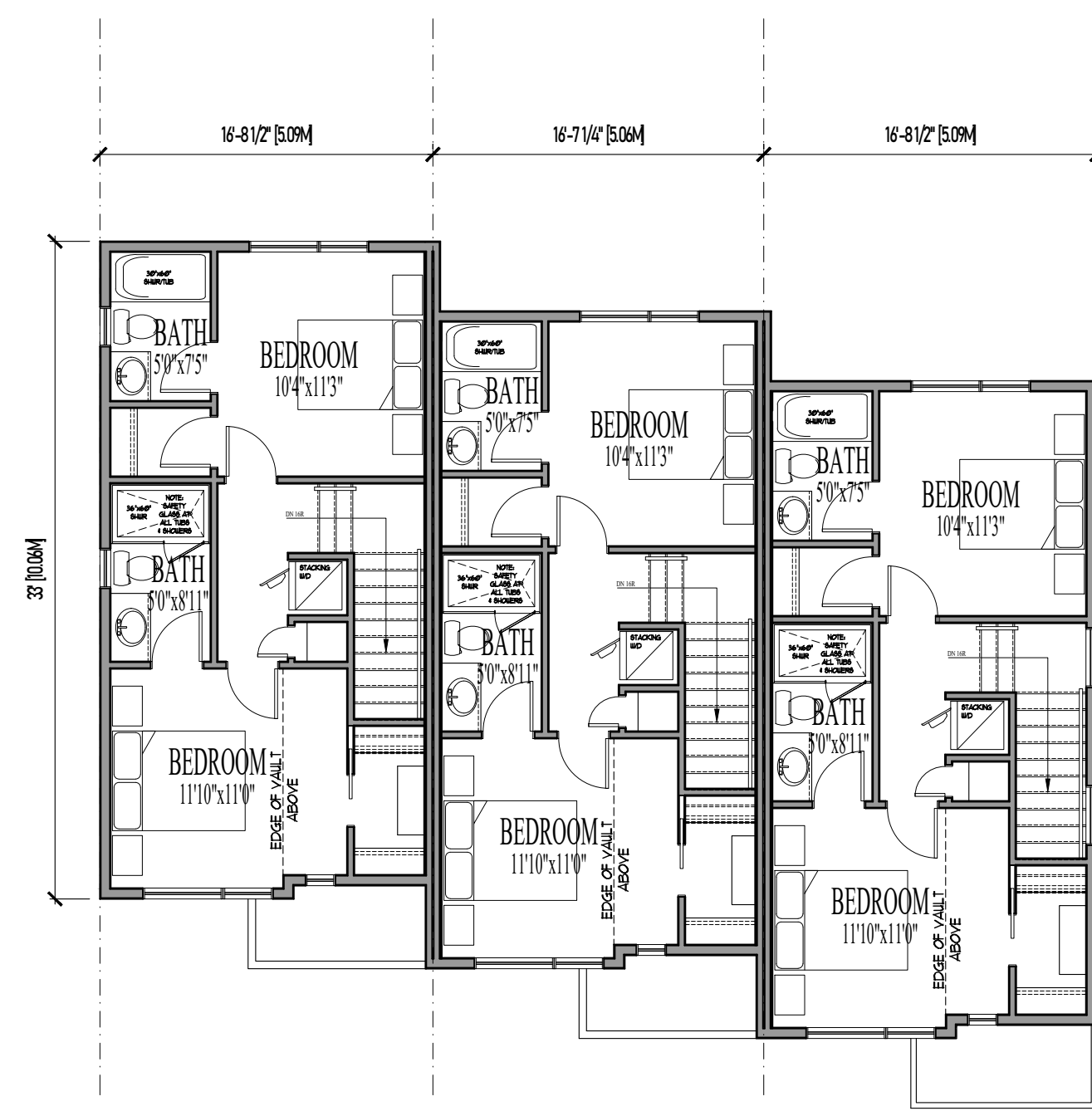

2 UPPER FLOOR PLAN-LOT A  
SCALE: 1/8"=1'0"



3 SOUTH ELEVATION - LOT A  
SCALE: 1/8"=1'0"

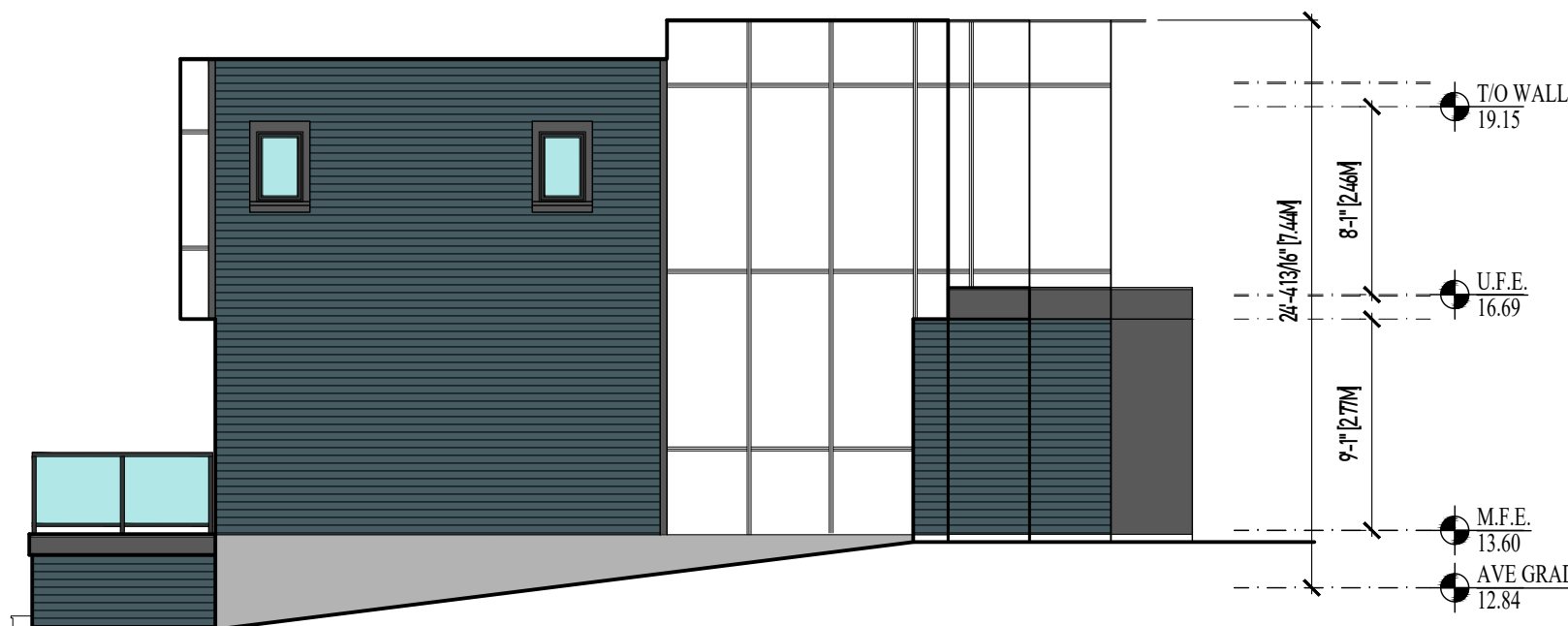

4 WEST ELEVATION - LOT A  
SCALE: 1/8"=1'0"

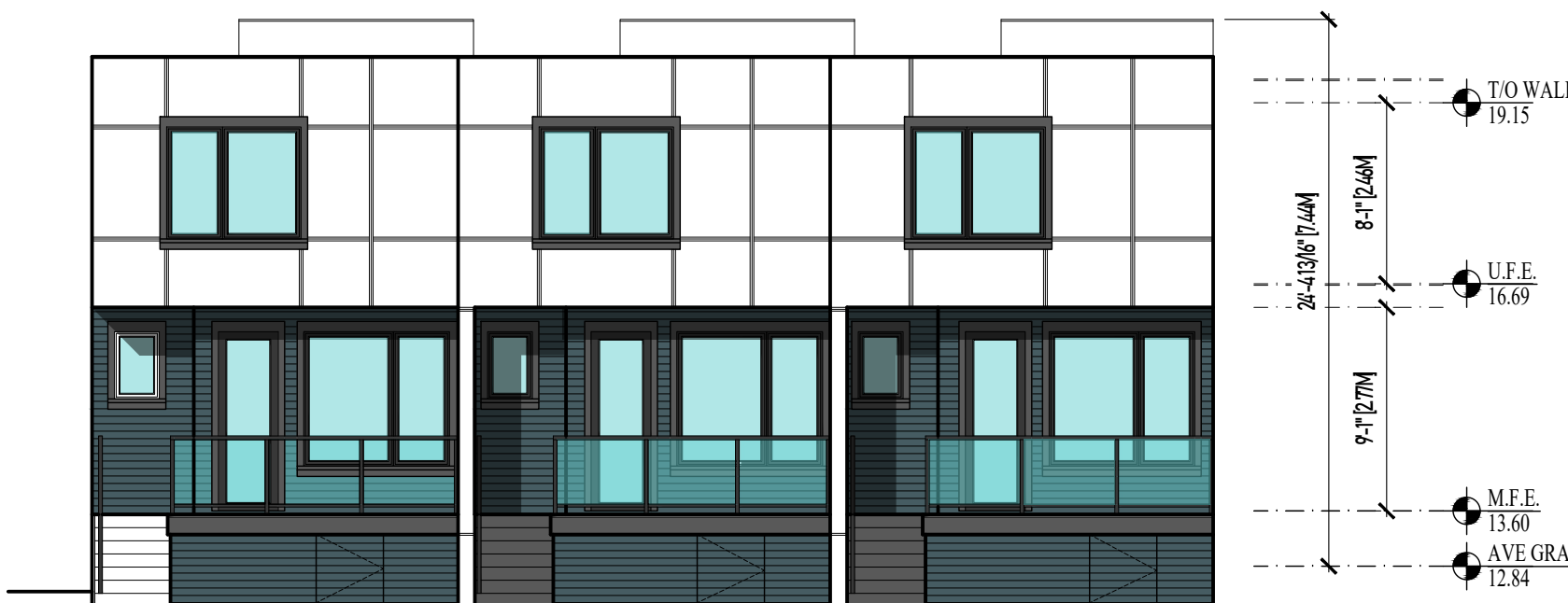

5 NORTH ELEVATION - LOT A  
SCALE: 1/8"=1'0"

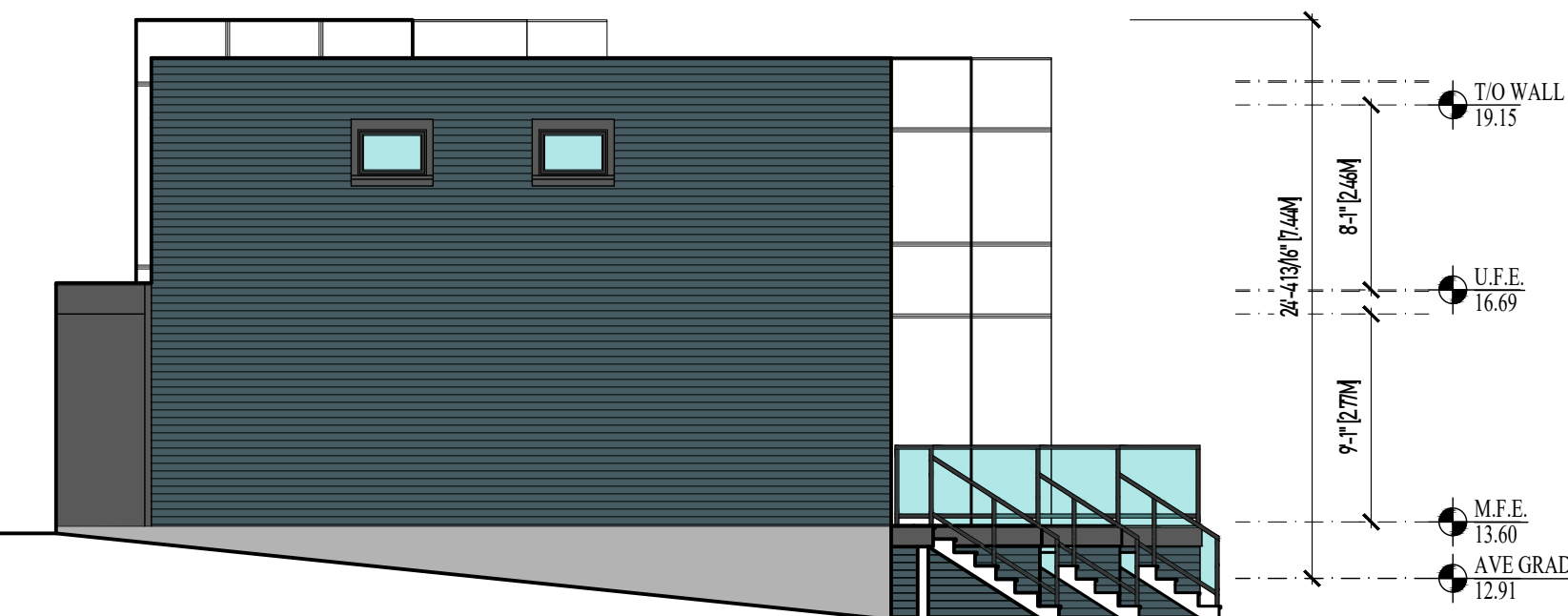

6 EAST ELEVATION - LOT A  
SCALE: 1/8"=1'0"

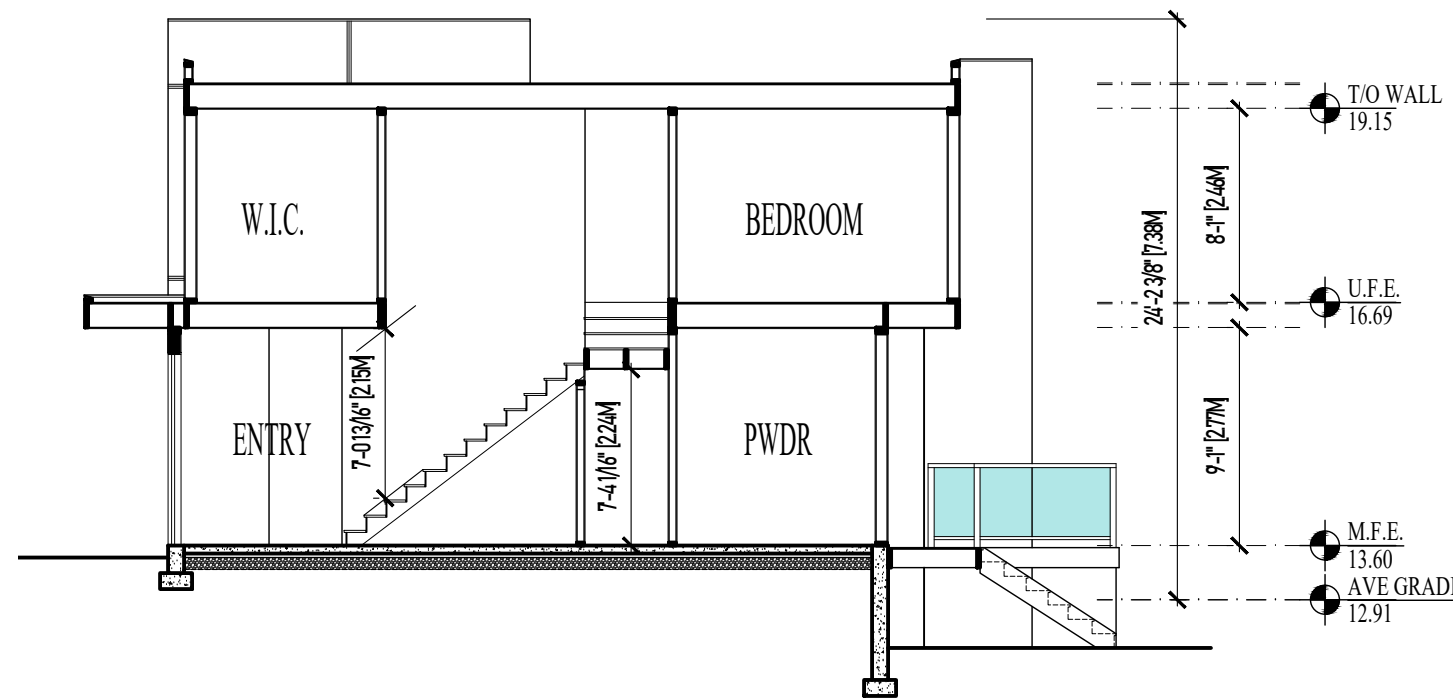

7 SECTION - LOT A  
SCALE: 1/8"=1'0"



8 STREETSCAPE - LOT B  
SCALE: 1/8"=1'0"

RE-ISSUED FOR DVP  
2025-09-12



1161 NEWPORT AVE  
Victoria, B.C. V8S 5E6  
Phone: (250) 360-2144  
Fax: (250) 360-2115

Drawn By: LOUIS HORVAT

Date: JANUARY 27, 2023

Scale: AS NOTED

Project:  
1073 COLVILLE ROAD  
REZONING AND  
SUBDIVISION

Title:  
LOT A PLANS AND  
ELEVATIONS, LOT B  
STREETSCAPE

Revision: Sheet:

A2

Proj.No.

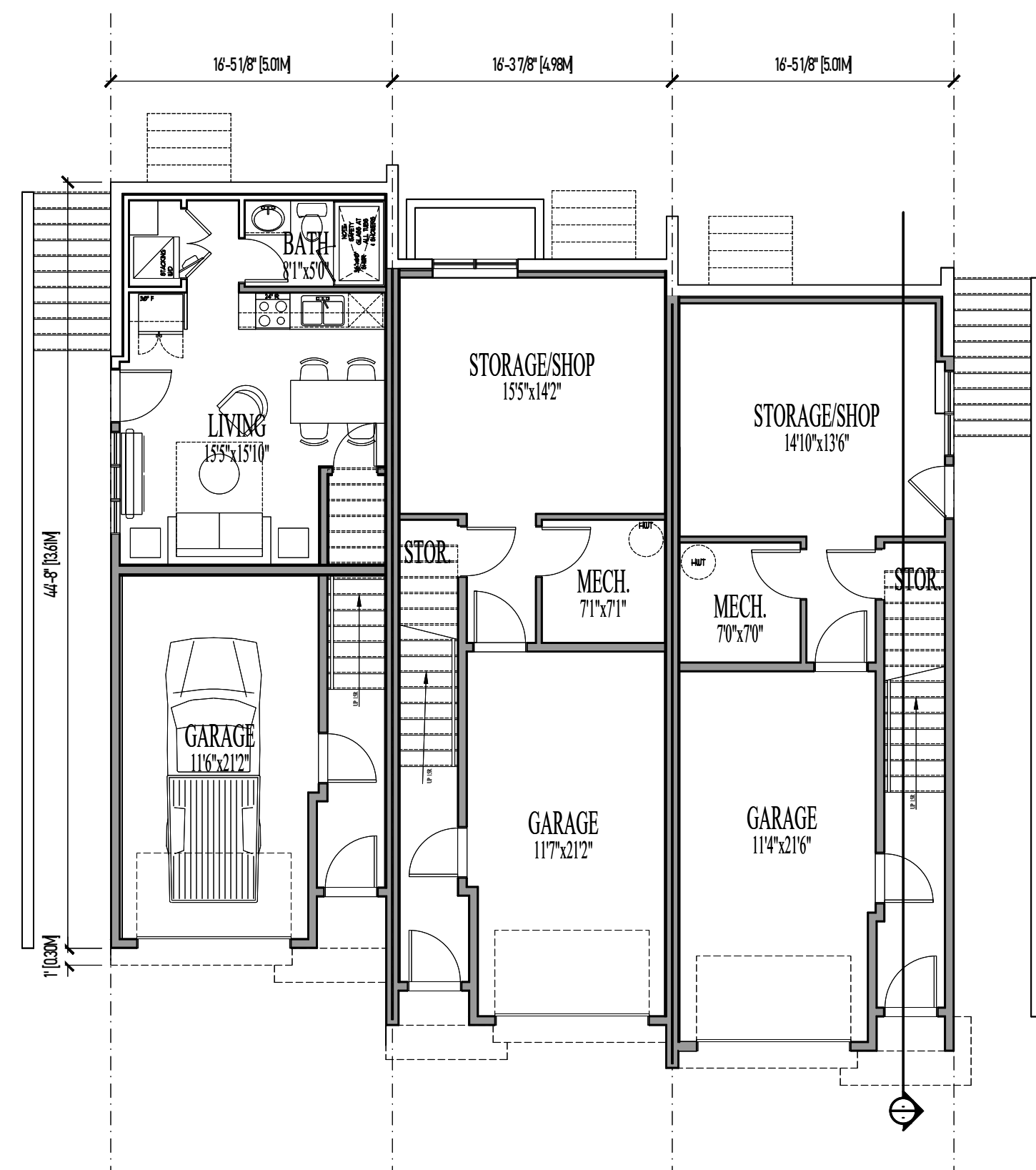

1 LOWER FLOOR PLAN-LOT B  
SCALE: 1/8"=1'-0"

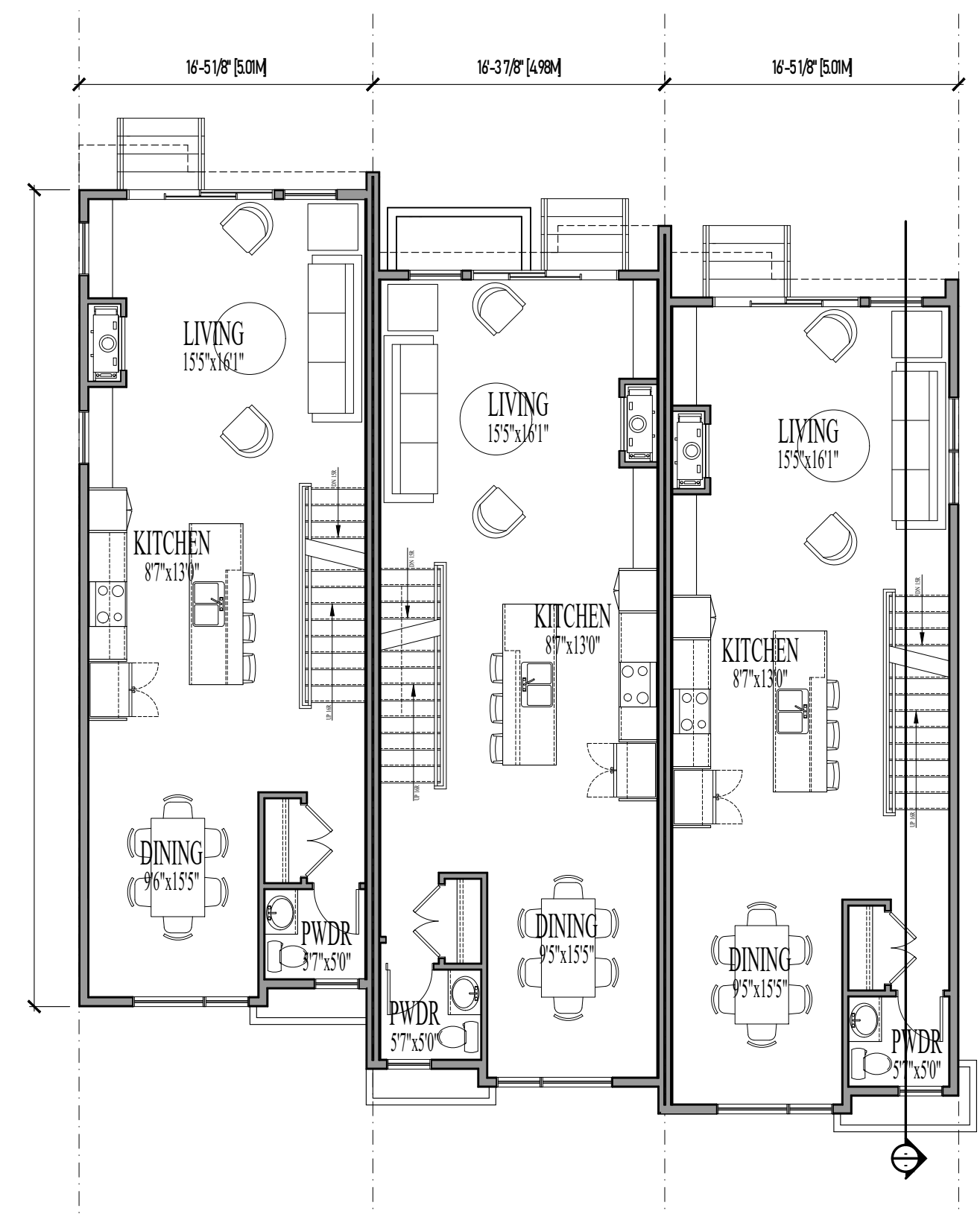

2 MAIN FLOOR PLAN-LOT B  
SCALE: 1/8"=1'-0"

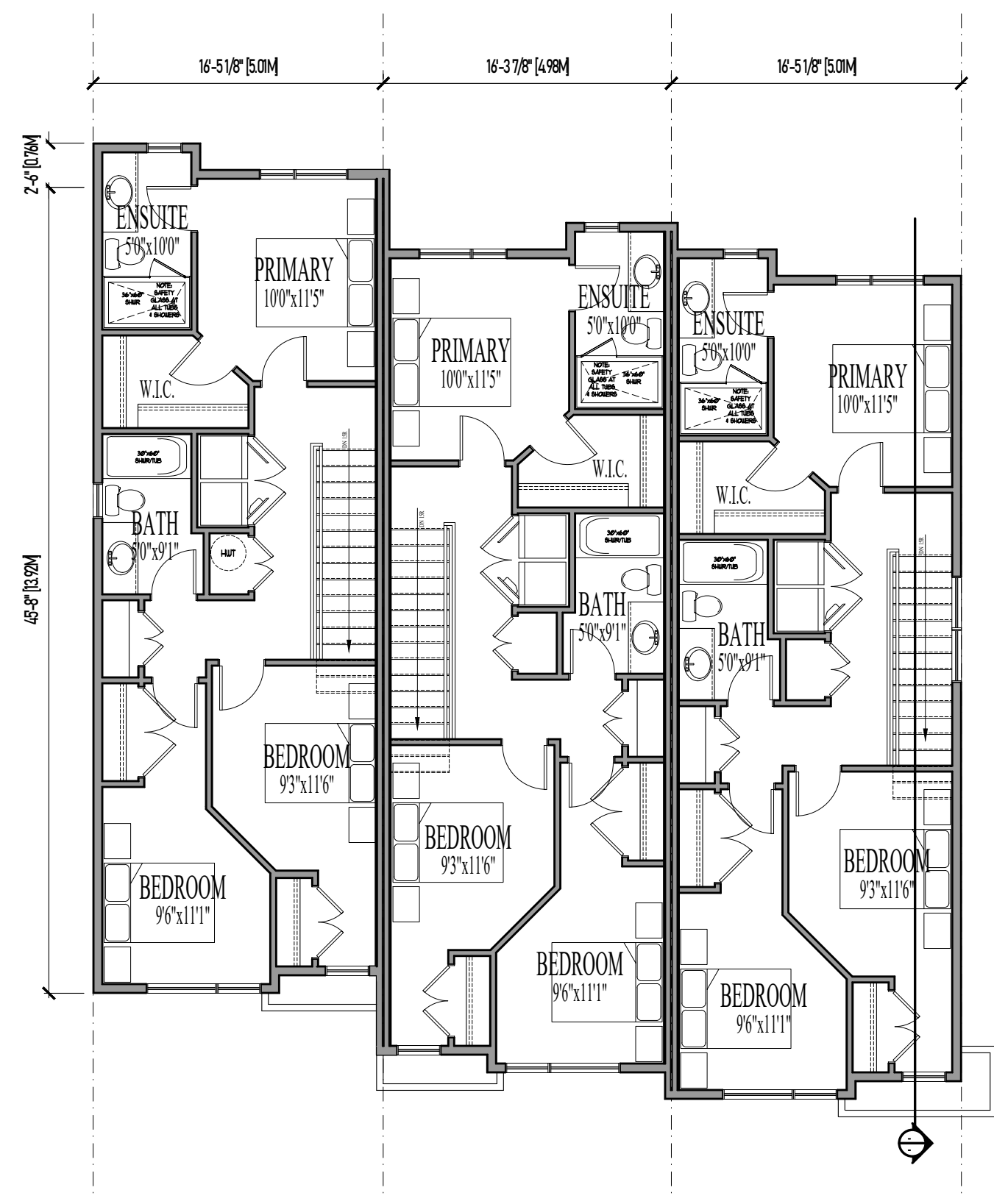

3 UPPER FLOOR PLAN-LOT B  
SCALE: 1/8"=1'-0"

FINISH SCHEDULE	
1	CEMENTITIOUS PANEL COLOUR: WHITE MANUFACTURER: JAMES HARDIE
2	CEMENTITIOUS PANEL COLOUR: DARK GREY MANUFACTURER: JAMES HARDIE
3	CEMENTITIOUS SIDING COLOUR: BLUE MANUFACTURER: JAMES HARDIE
4	PREFINISHED METAL COLOUR: DARK GREY MANUFACTURER: -
GENERAL NOTES: - WINDOW OPERATION SHALL BE PER OWNER'S DIRECTION AND CONFORM TO B.C.B.C. 2018 REQUIREMENTS FOR EGRESS - FLASH OVER ALL MATERIAL TRANSITIONS, AND DOOR & WINDOW HEADS - NO COMBED-FACED TRIM - ALL COLOURS BY DESIGNED AND OWNER	



4 NORTH ELEVATION - LOT B  
SCALE: 1/8"=1'-0"

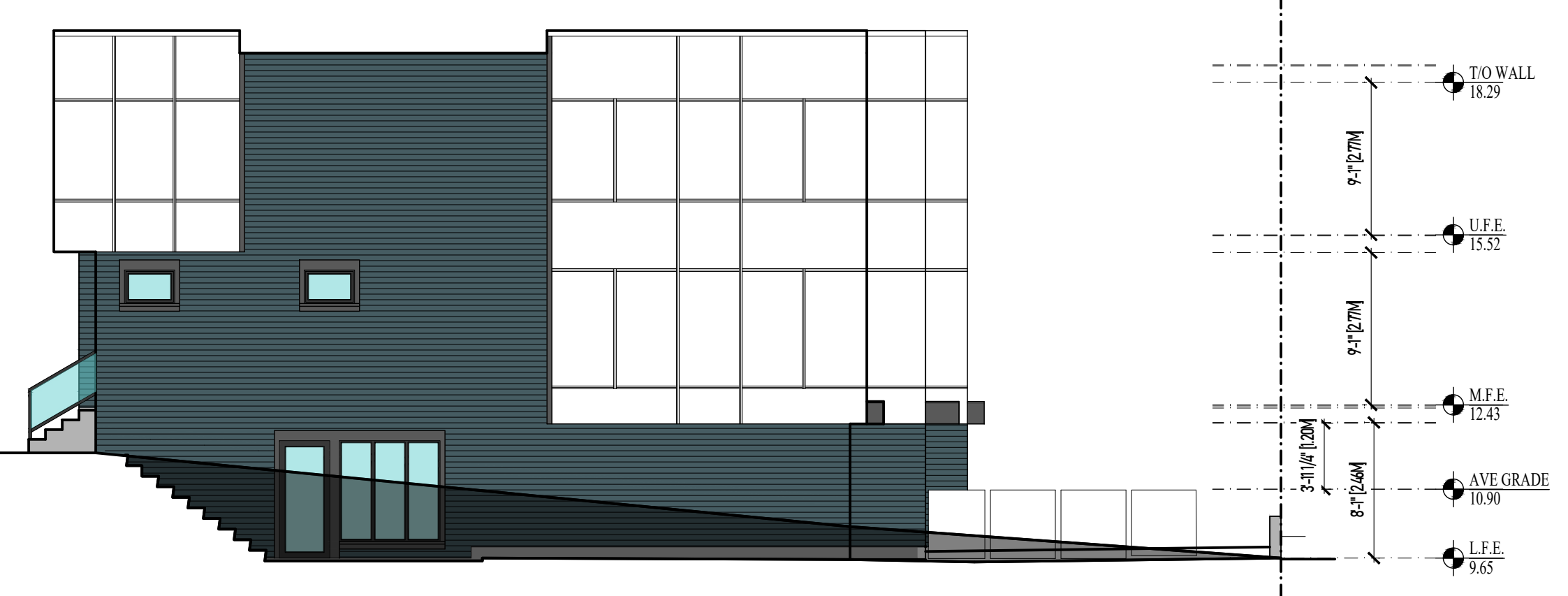

5 EAST ELEVATION - LOT B  
SCALE: 1/8"=1'-0"



6 SOUTH ELEVATION - LOT B  
SCALE: 1/8"=1'-0"

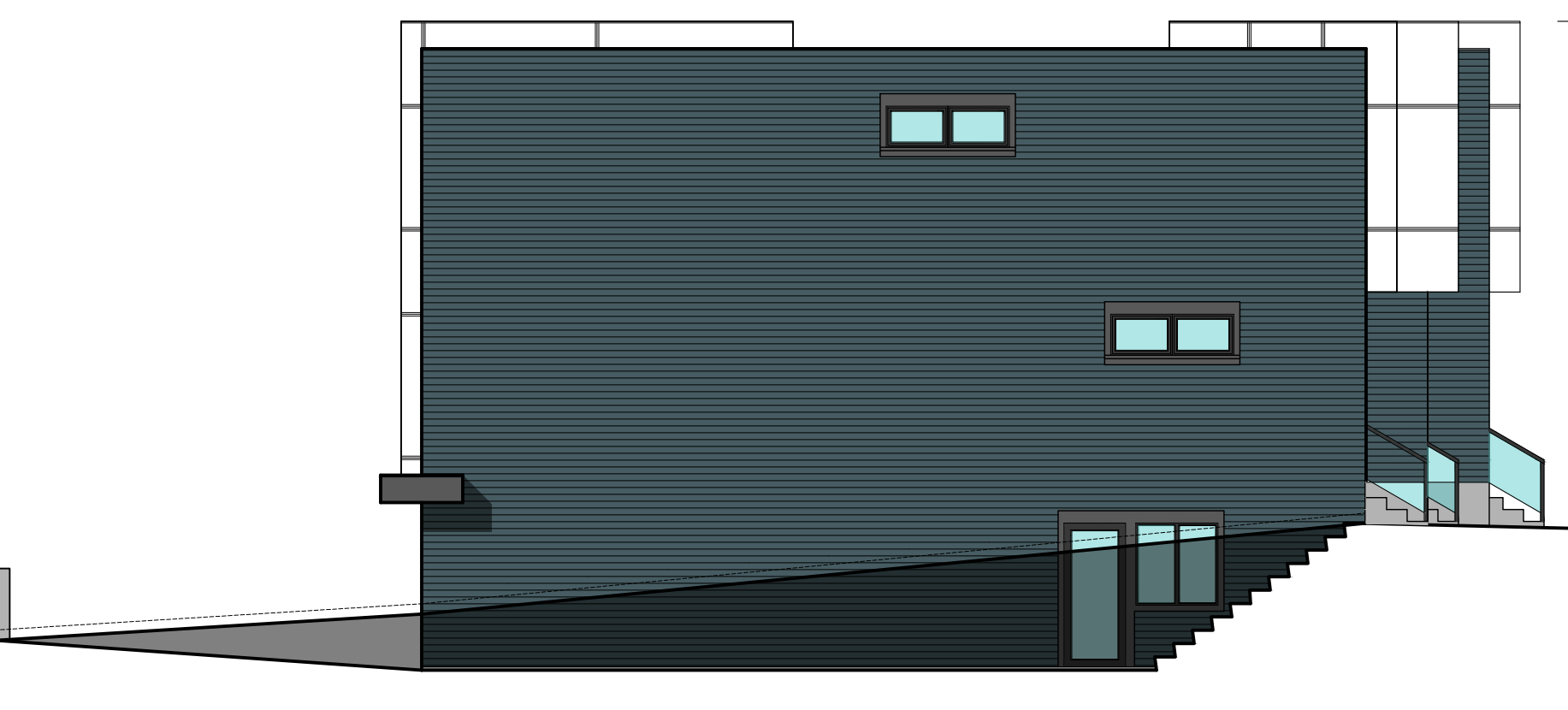

7 WEST ELEVATION - LOT B  
SCALE: 1/8"=1'-0"

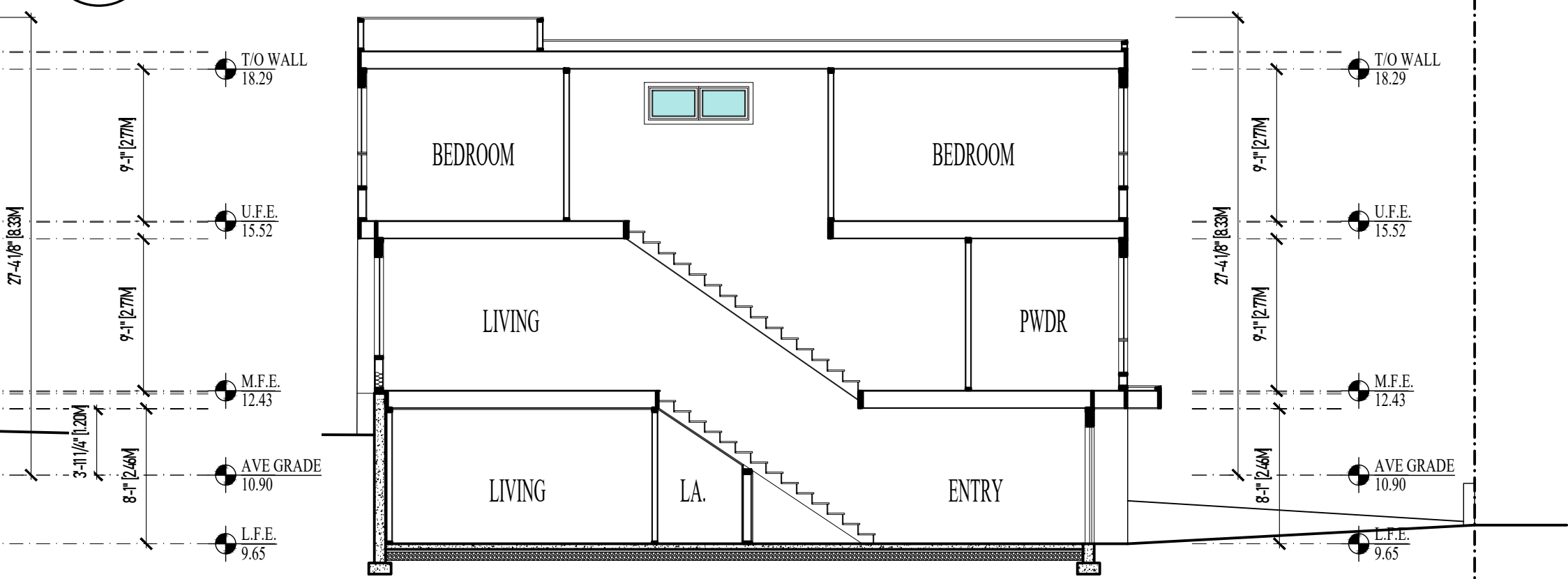

8 SECTION - LOT B  
SCALE: 1/8"=1'-0"

RE-ISSUED FOR DVP  
2025-09-12



1161 NEWPORT AVE  
Victoria, B.C. V8S 5E6  
Phone: (250) 360-2144  
Fax: (250) 360-2115

Drawn By: LOUIS HORVAT  
Date: JANUARY 27, 2023  
Scale: AS NOTED

Project:  
1073 COLVILLE ROAD  
REZONING AND  
SUBDIVISION

Title:  
LOT B PLANS AND  
ELEVATIONS

Revision:	Sheet:
	<b>A3</b>
	Proj.No.

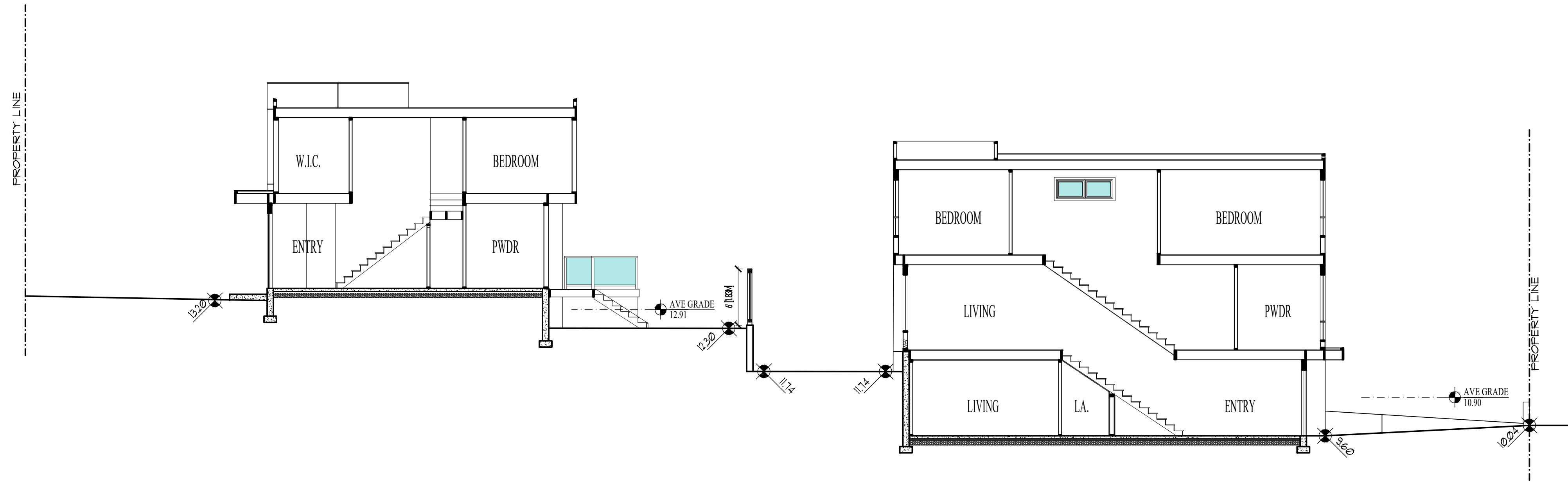

1 SITE SECTION  
A04 SCALE: 1/8"=1'-0"

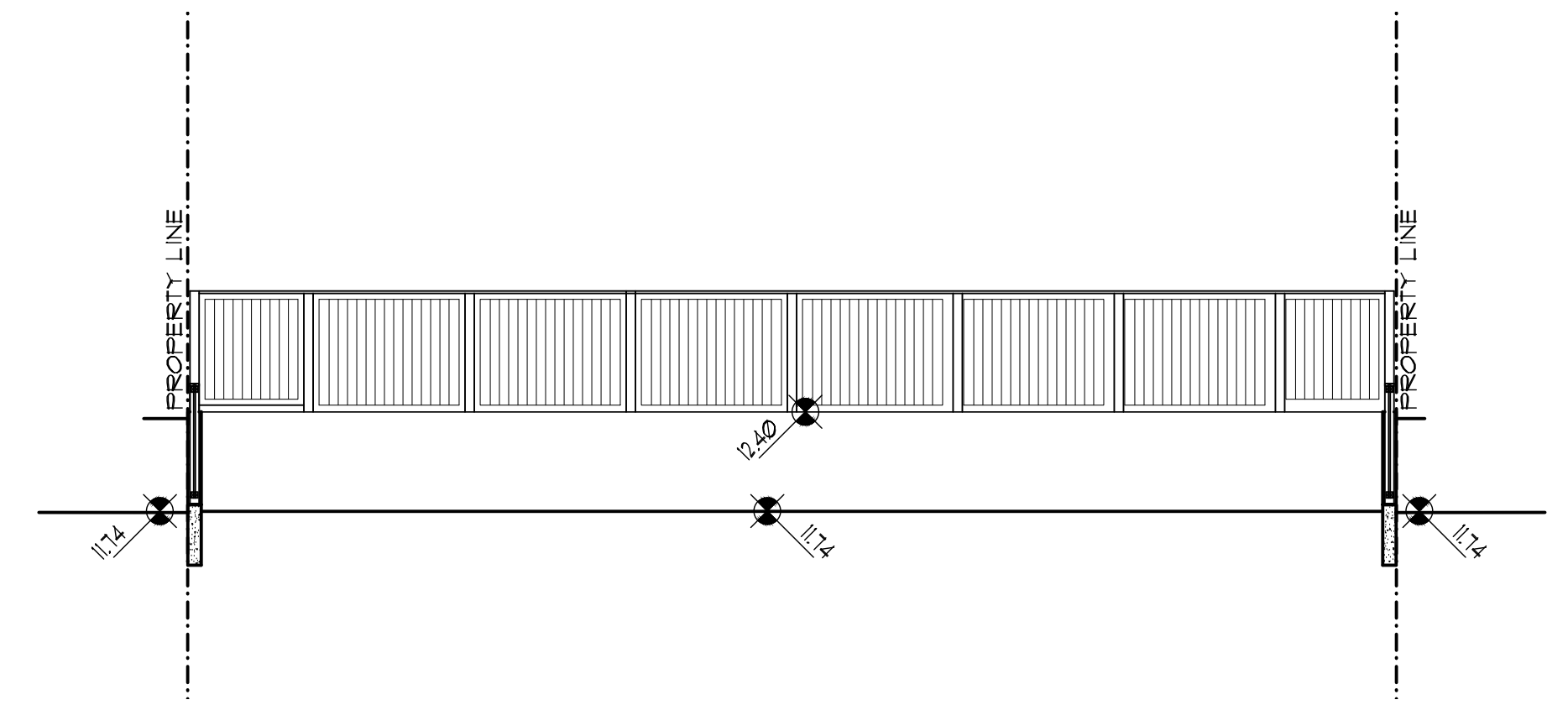

2 SITE SECTION  
A04 SCALE: 1/8"=1'-0"

RE-ISSUED FOR DVP  
2025-09-12



1161 NEWPORT AVE

Victoria, B.C. V8S 5E6  
Phone: (250) 360-2144  
Fax: (250) 360-2115

Drawn By: LOUIS HORVAT

Date: JANUARY 27, 2023

Scale: AS NOTED

Project:  
1073 COLVILLE ROAD  
REZONING AND  
SUBDIVISION

Title:  
SITE SECTIONS

Revision:

Sheet:

A4

Proj.No.